



Directional Control Valves
Technical Information
Model 1622



DESCRIPTION

Two-spool series circuit monoblock valve. 66 l/min [17 US gal/min] maximum flow. 207 bar [3000 psi] maximum pressure.

TYPICAL APPLICATIONS

Tractor loaders, skid steer loaders, sweepers, mowers, trenchers, agricultural equipment, tree removal equipment, forklifts

STANDARD FEATURES

- All valves supplied with clevis end spools
- Power-beyond port machined and plugged (use whenever a downstream valve is required)
- Cast-iron body
- Chrome plated spools select fit to body for leakage control
- Paint color: black primer
- Closed-transition spool timing prevents load drop before raise
- Individually boxed and labeled



Directional Control Valves

Technical Information

Model 1622

PRESSURE DROP

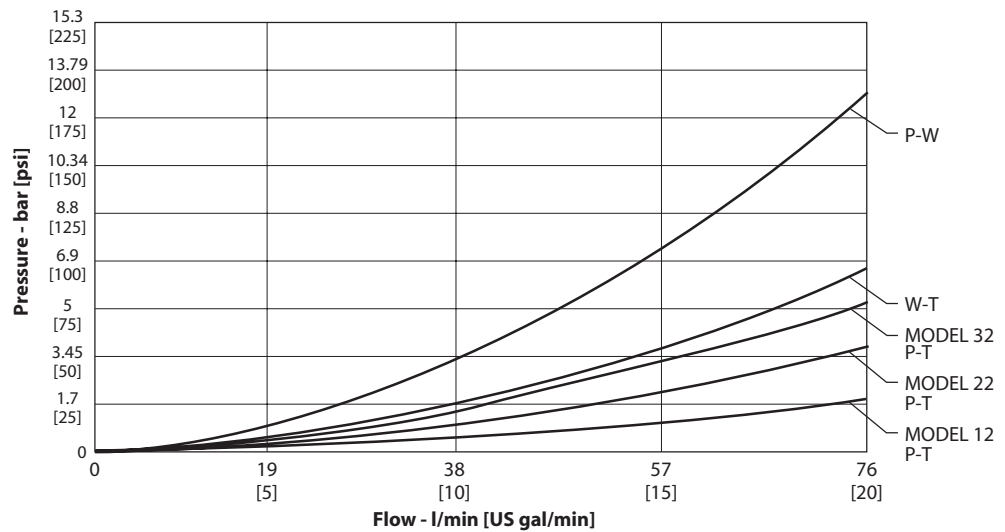

PORTING

Inlet/outlet	7/8-14, SAE (standard) 3/4-16 SAE
Locations available	top and side
Work ports	3/4-16, SAE (standard)

HANDLES

- C-hook kit
- Standard handle with C-hook kit
- Pivot-block handle kit

TECHNICAL DATA

Maximum pressure	207 bar	[3000 psi]
Maximum tank line pressure	69 bar	[1000 psi]
Maximum oil flow	66 l/min	[17 US gal/min]
Spool travel in and out from neutral	6.3 mm	[0.25 in]
Spool travel to float position from neutral	12.6 mm	[0.50 in]
Maximum port leakage at 69 bar [1000 psi] 21 mm²/sec (cSt) [102 SUS]	24 cm ³ /min	[1.46 in ³ /min]
Maximum lift check leakage at 69 bar [1000 psi] 21 mm²/sec (cSt) [102 SUS]	82 cm ³ /min	[82 cm ³ /min]
Minimum oil temperature	-29° C	[-20° F]
Maximum oil temperature	82° C	[180° F]
Ambient temperature range	-29° to 60° C	[-20° to 140° F]
Minimum viscosity	6 mm ² /sec (cSt)	[45 SUS]
Maximum viscosity	440 mm ² /sec (cSt)	[2000 SUS]
Fluid cleanliness per ISO 4406	19/16	
Typical spool effort: dry, full stroke	231 N	[52 lbf]



Directional Control Valves

Technical Information

Model 1622

OPTIONS

Spool types

Symbol	Description
	Series float
	Tandem center float (spool next to outlet)
	Tandem center motor (spool next to outlet only)
	3-way tandem center (spool next to outlet)
	4-way series
	4-way tandem (spool next to outlet)
	3-way tandem center (spool next to outlet)



Directional Control Valves

Technical Information

Model 1622

OPTIONS

Spool action

- Spring center
- Detent in, detent out, and three position detent
- Detent in float
- Motor start switches

Relief valve

Direct acting ball and spring

- 0.9 bar per liter [50 psi per gallon] rise
- Not for use on settings over 30 l/min [8 US gal/min].
Full flow setting at 138 bar [2000 psi]
- Adjustable is standard, tamper-proof cap is optional.

Pilot operated relief valve

- 0.4 bar per liter [20 psi per gallon] rise
- No restrictions on setting up to 207 bar [3000 psi]
- Adjustable standard, tamper-proof is optional.



Directional Control Valves
Technical Information
Model 1622

DIMENSIONS

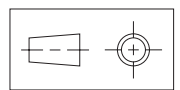
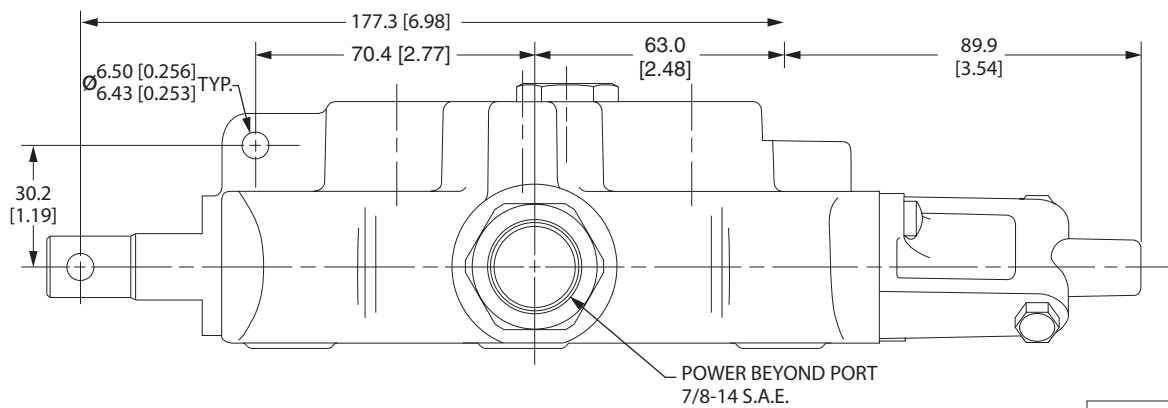
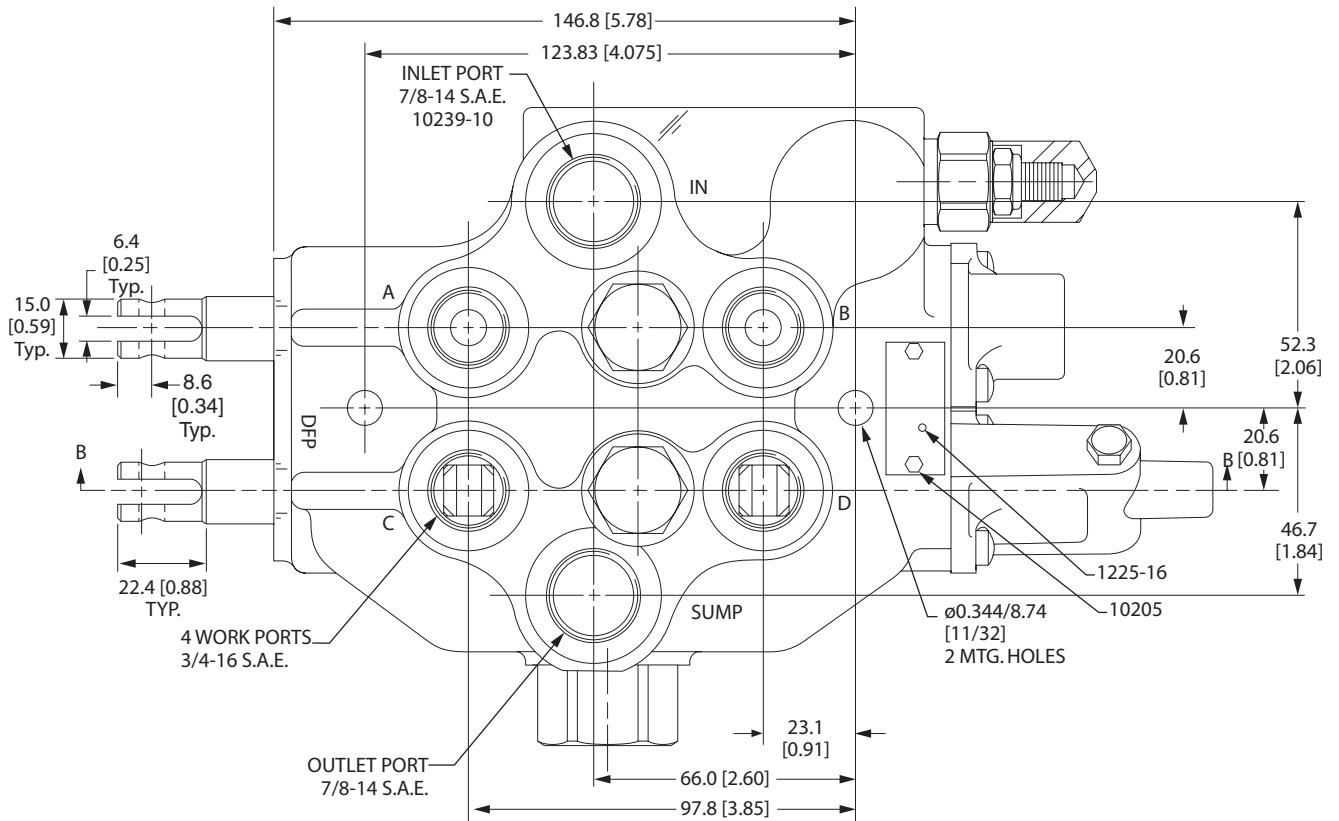

mm [in]